

# AntiKippenLights-Atmel Construction Kit

## Contents:

- 1 PCB "AKL-Atmel"
- 1 Controller ATtiny2313-20PU
- 1 20-pin IC socket
- 20 LEDs 5mm red, low current
- 1 Push-button
- 1 Terminal Block
- 6 Resistors 47  $\Omega$
- 1 Ceramic capacitor 100 nF
- 1 Battery Holder 2x AA
- 1 Battery Clip (for battery holder)

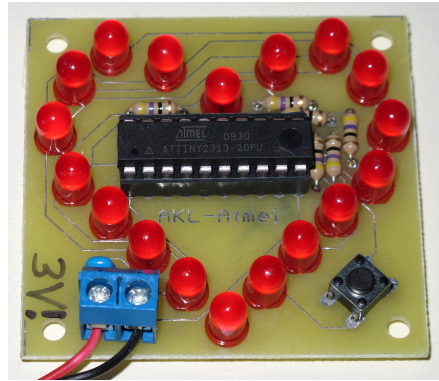

## General Soldering Advice

Insert the components one at a time and bend the leads outward slightly to prevent the component from falling out. Heat up the solder joint for a second before feeding some solder wire between the soldering iron's tip, the board and the component's lead. Wait for a few more seconds before removing the tip from the solder joint. Don't move the board before the solder has solidified. After soldering, trim the leads with a wire cutter to about 1-2 mm length.

See [http://mightyohm.com/files/soldercomic/FullSolderComic\\_EN.pdf](http://mightyohm.com/files/soldercomic/FullSolderComic_EN.pdf) for more detailed instructions.

I recommended soldering the components in the order listed below. Make sure the board is the right way up (component outlines visible, see image) before starting.

**1. Resistors (R1 ~ R6):** Bend the leads 90° as close to the resistor body as possible before inserting them into the board. Orientation doesn't matter.



**2. IC Socket (IC1):** Insert the IC socket into the board, making sure the orientation of the small notch matches the image. You can bend two diagonally opposite pins of the socket if you like, but setting the board with the socket inserted upside-down on a flat surface usually works just as well.



**3. Push-button (S1):** Insert the push-button to the intended location on the board. The push-button will fit in two orientations, you can use either of them.

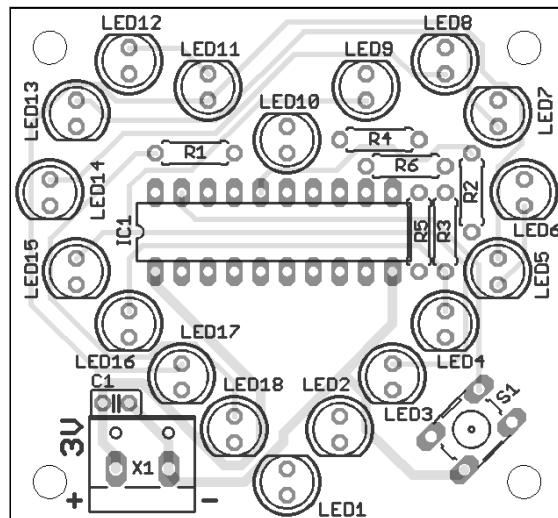

**4. Capacitor (C1):** Insert the capacitor in the location just above the terminal block. Bend the leads outward before soldering. The capacitor is marked '104' for  $10 \cdot 10^4$  pF = 100 nF. The orientation doesn't matter.



**5. LEDs (LED1 ~ LED18):** The orientation is important for the LEDs. Make sure the flat side of the LED (cathode) matches the outline in the image. The flat side of the LED also corresponds to the shorter lead. Start with 3 or 4 LEDs, one in each corner, then add the other LEDs one at a time. Don't solder too long on the LEDs, they will have reduced brightness if they become too hot during soldering. The kit contains two spare LEDs in case you break or lose some of the LEDs.



**6. Terminal Block (X1):** Insert the terminal block, turn the board over and solder it. Orientation doesn't matter, but it is recommended that the openings face toward the edge of the board.



**7. Controller (IC1):** Insert the controller into the IC socket. Make sure the controller's notch matches that of the socket. Sometimes, the notch is replaced by a tiny dot near pin one, which should also face toward the notch of the socket.

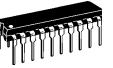

**8. Battery Clip:** Bend the exposed sections of the wires back to lie flat against the insulation. Insert the wires into the terminal block and fasten the screws. Sometimes you will need to loosen the screws before you can insert the wires. The red wire goes into the left terminal (marked with a "+" on the board), the black wire goes into the right terminal (marked with a "-" on the board).

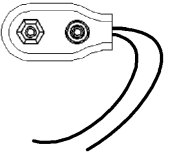

**9. Batteries:** Insert two AA batteries (not included) into the battery holder and connect the battery clip to the battery holder. **Never connect a 9 V battery!**

**Turn it on!** Push the button and the animation should start right away. If it doesn't, disconnect the batteries immediately and start looking for mistakes. If an LED is on most of the time (even with the circuit switched off), it is likely you inserted it the wrong way. You can remove it by heating both pins at the same time with a soldering iron while gently pulling on the LED (with your fingers or needle-nose pliers), then use desoldering braid or a desoldering pump to get the remaining solder out of the holes.

If you don't want to use the on/off button, you can solder a bridge between controller pins 10 and 9 (J1). This will cause the circuit to turn on automatically when power is applied, the button is ignored.

**Questions? Problems? Comments?** Please contact me!  
E-Mail: [arne@blinkenarea.org](mailto:arne@blinkenarea.org) • XMPP: [ArneRossius@jabber.ccc.de](xmpp:ArneRossius@jabber.ccc.de)

## Project webpage

German: <http://wiki.blinkenarea.org/index.php/AntiKippenLights-Atmel>

English: <http://wiki.blinkenarea.org/index.php/AntiKippenLights-AtmelEnglish>